

ANALOGUE TO FREQUENCY CONVERTER

TYPE B12-5

- **Wide range of input signal types**
- **Frequency ranges from 0 - 0.001Hz up to 0 - 10kHz**
- **Dual outputs:-**
1: Open collector, Voltage pulse or Electromechanical counter options
2: TTL
- **Performs integration when connected to an external totaliser**
- **Universal AC/DC powered (85 - 260 VAC, 24 - 200 VDC)**
- **Maintains loop on mA inputs when module unplugged**
- **Wall or DIN rail mounting**



The Analogue to Frequency Converter converts a process signal input (voltage or current) into a pulsed output with respect to time. The output pulse rate is proportional to the magnitude of the analogue input signal.

Information required when ordering

- Specify order code **B12-5** followed by:-
- Input signal type (see specification)
- Output No. 1 type (see specification)
- Output pulse rate at full scale
... or if to be used as an integrator
i.e. output driving a totaliser / counter:-
 - Full Scale Rate represented by input signal (e.g. Full Scale Input = 10m³ per day)
 - The integrated quantity represented by one output pulse (e.g. 1 pulse = 1 litre)
- Low level cut-off (5% unless otherwise specified - see specification)

Typical applications

- » Converting analogue process signals into a pulsed output suitable for PLC digital inputs
- » Integration of process 'rate' measurements e.g. from energy meters and flowmeters
- » Proportional sampling applications

Specifications

Inputs *(factory configured)*

Input impedances shown in brackets.

Current: 0-10 mA (100R), 0-20 mA (50R), 4-20 mA (62R)

Voltage: 0-1V, 0-5V, 0-10V (>200k)

(Other inputs available to order)

Input overrange protection

Self resetting 100mA fuse

Outputs

Output 1: *(factory configured options)*

- a) Optically isolated open collector
- b) for electromechanical counter - 24V 60ms
(NB external counter impedance must be $\geq 80R$)
- c) Voltage pulse (up to 24V)

Output 2: TTL *(always available as a second output)*

Output pulse rate

Calibrated as required between the following full scale limits:-

- Minimum: 0.001 pulses per second
- Maximum: 10000 pulses per second

Calibrated accuracy

Set at 100% to be within $\pm 0.1\%$ FSD

Linearity error

$\leq \pm 0.1\%$ FSD.

Output pulse width

As standard, the pulse width is approximately 65ms.

NB for pulse rates greater than 7.7Hz, the output waveform reverts to equal mark - space.

Zero (low-level) cut-off

0 — 10% *(set to 5% FSD unless otherwise requested).*

Temperature coefficients

Zero: $\pm 0.02\%$ span/ $^{\circ}C$, Span: $\pm 0.02\%$ span/ $^{\circ}C$

Environmental

Temperature range: operating -10 to +50 deg C
storage -20 to +70 deg C

Humidity: 0-95% RH non-condensing

Stability

Over 24 hours $\pm 0.05\%$ FSD; Over 1 year $\pm 0.1\%$ FSD

Isolation

Input and outputs are isolated from the power supply. The outputs are isolated from the input but not from each other.

Maximum voltage 250V RMS or 400V DC.

Resistance $\geq 50 \times 10^6$ ohms measured at 1000 V DC.

Power supply

85 - 260 VAC 50/60Hz; 24 - 200 VDC (3W nominal)

Mechanical

Weight: approx. 0.5kg

Enclosure: Fire retardent materials - PPO base, ABS cover

Screw terminal wire capacity: 2 x 1.5mm²

Dimensions:

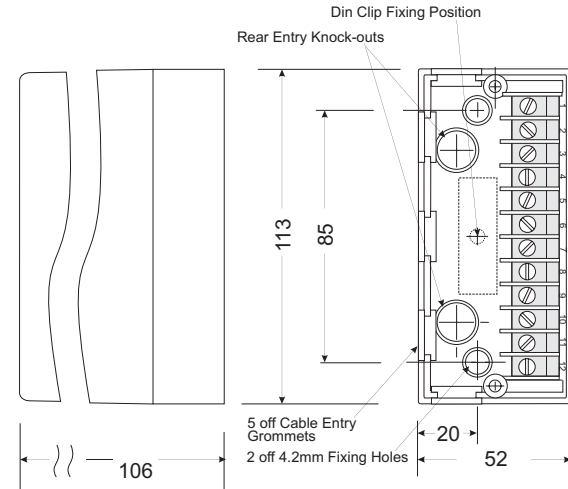

Safety & EMC

Safety: EN61010-1, Emissions: EN50081-1

Immunity: EN50082-1, CE certified

Electrical connections



Please note: these details are provided for pre-sales information only. Installation must be carried out in accordance with the User Guide.

- 1 — Reserved
- 2 — Input Signal (+)
- 3 — Input Signal (-)
- 4 — Reserved
- 5 — Reserved
- 6 — Output 0V
- 7 — TTL output
- 8 — Open collector Output
- 9 — +24V (counter connection)
- 10 — Earth
- 11 — Neutral / — DC
- 12 — Line/ + DC



THIS UNIT CAN BE MAINS POWERED, AND ALL INPUTS TO IT MUST BE ISOLATED FROM DANGEROUS VOLTAGES BEFORE THE FRONT COVER IS REMOVED. LIVE TERMINALS WILL BE EXPOSED.

Continuous development may necessitate changes in these details without notice

SIL[®]

STROUD INSTRUMENTS LTD.
36-40 Slad Road, Stroud, Glos. GL5 1QW, England
Telephone: +44 (0)1453 765433 Fax No: +44 (0)1453 764256
www.sil.co.uk