

SET-POINT GENERATOR
Types B12-1A, B12-1F & B12-1RP
User Guide

Continuous development may necessitate
changes in these details without notice

Document Ref: UDB12-1A.vp Rev 0



PROCESS MEASUREMENT, CONTROL & DISPLAY INSTRUMENTATION

STROUD INSTRUMENTS LTD

36-40 Slad Road, Stroud, Gloucestershire GL5 1QW England

Tel: +44 (0)1453 765433 Fax: +44 (0)1453 764256

sales@sil.co.uk <http://www.sil.co.uk>

Contents

Safety instructions / warnings	1
Installation	2
Location	2
Fixing	2
Dimensions and fixing positions	2
Wiring and connections	3
Access to terminals	3
Input connections	3
Output connections	3
Power supply connections	4
Span and zero adjustment (<i>if applicable</i>)	4
Fuse replacement and power supply adjustment	4
Fuse replacement	5
Changing AC supply voltage.	5
Appendices	
1 - Specification	6



WARNING!

It is important that this guide is read and fully understood before attempting installation or commissioning of the instrument. Instructions appearing in this document, and current safety legislation, must be observed to ensure personal safety and to prevent damage to the instrument or equipment connected to it.

The instrument should be installed, commissioned and operated *only* by suitably qualified and authorised personnel.

Safety and EMC information

Safety: EN61010 -1

Immunity: EN50082-1

Emissions: EN50081-1

CE certified



The specifications for the instrument must not be exceeded. If the instrument is used in a manner not specified, the protection provided by the instrument may be compromised.



The instrument must be installed in an enclosure that provides adequate protection against electric shock.



Ensure that power to the instrument is switched off and signal wiring isolated from hazardous voltages before carrying out installation or maintenance.



The instrument is designed for installation in a clean, dry environment (Pollution degree 1).



Stroud Instruments Ltd strongly recommends that repairs and re-calibration work are done on a return to factory basis in order that our quality standards, product specifications and safety precautions are not compromised.



The instrument is double insulated

Note: Clean with a moist cloth - USE NO SOLVENTS.

Installation



WARNING: Installation should be conducted by appropriately skilled and authorised personnel only.



WARNING: Ensure that power to the instrument is switched off and signal wiring isolated from hazardous voltages before carrying out installation.



WARNING: The instrument must be installed in an enclosure that provides adequate protection against electric shock.

Location

- The instrument is designed for installation in a clean, dry environment
- Do not install near to switch gear, motor controllers or other sources of strong magnetic fields.
- Avoid exposure to direct sunlight and ensure the ambient temperature inside the enclosure that the unit is mounted in will not exceed our specification.

Fixing

B12 Series Modules are designed to be fitted to a flat dry surface using two 4mm screws. Alternatively, by fitting an optional DIN clip, they may be clipped to a rail conforming to BS5584:1978, EN50 022, DIN46277-3.

Grommets are provided on three sides of the base section and there are two rear entry knock outs in the bottom.

To gain access to fixing points:

- (i) Remove the plug-in module securing screws.
- (ii) Gently pull away the plug-in module from the base section.

- (iii) To refit the module, align the module edge connectors with the socket in the base and carefully press home. NB do not overtighten the module securing screws.

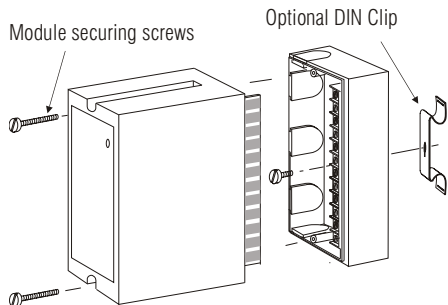

Dimensions and fixing positions

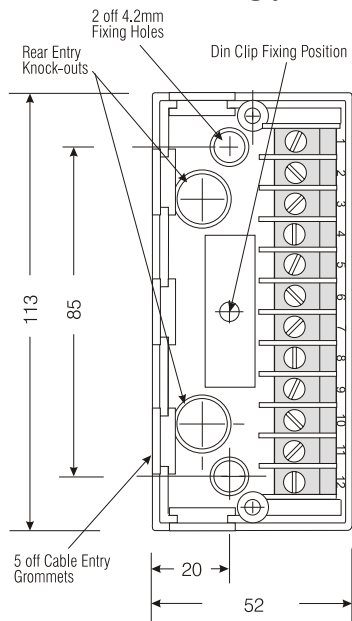

Depth of unit 106mm

Wiring and connections

- Segregate power supply and signal wiring.
- Use screened cable for all signal wiring with the screen earthed at instrument end only.
- All connections should be made using ferrules.

Screw terminals are provided - wire capacity 2 x 1.5mm² (approx. 16 AWG).

Access to terminals



WARNING: Ensure that power to the instrument is switched off and signal wiring isolated from hazardous voltages

Loosen the two module securing screws. Gently pull away the top section of the module from its base to expose the fixing points and wiring terminals. To refit the module, align the module edge connectors with the socket in the base and carefully press home. **NB** do not over tighten the module securing screws.

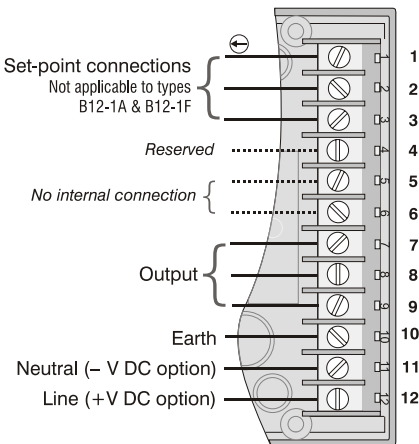

Input connections

B12-1RP remote set-point only

Note: This section applies only to the Set-point Generator Type B12-1RP which has a remote set-point control.

The set-point type is factory configured for the application specified - see data label on enclosure for details of the type.

Remote set-point potentiometer connections

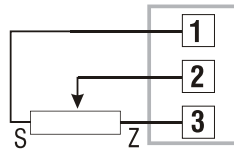

Output connections

Outputs are factory configured for one type of input only - see data label on enclosure for details of the type fitted, and are not user configurable.

Voltage output

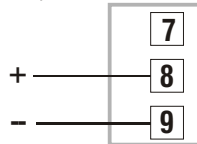

Current output

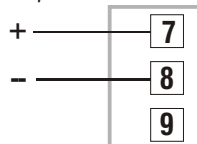

Current sink output

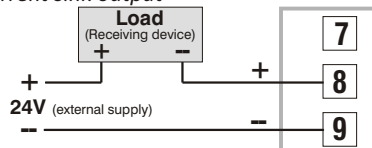

Power supply connections

This instrument is supplied in *one* of two power supply versions.

1. AC mains supply either: 110V, 220V or 230V \pm 50/60Hz, 5VA.
2. Low voltage supply: 11-32VDC 4W / 12-24VAC.



WARNING: Check that the supply voltage on the data label (on side of instrument) is suitable for the application.



WARNING: Ferrules must be used for AC mains power wiring

Power supply wiring to the instrument should be protected by a suitable fuse and double pole switch - *see below*. The switch should be clearly marked as the isolating switch for the instrument.

AC supply

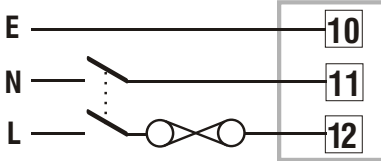

DC supply

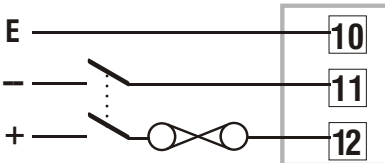

Span and Zero adjustment

B12-1RP remote set-point only

The Span and Zero controls, accessed through the holes in the front panel, will enable small adjustments to the calibration to be made.

- (i) **Set output Zero:** with the input signal at its zero setting, monitor the output signal with a suitable instrument and adjust the zero control.
- (ii) **Set output Span:** with the input at full scale adjust the span control.
- (iii) Repeat steps (i) and (ii) readjusting if necessary.

Fuse replacement and power supply adjustments



WARNING: Switch off all supplies and isolate signal and other wiring from dangerous voltages before proceeding.

Please note: the operating supply voltage on DC and 24V AC powered versions cannot be changed by the user.

Access to internal settings



WARNING: Switch off all supplies and isolate signal and other wiring from dangerous voltages before proceeding.

- (i) Remove plug-in module as described in Access to Terminals in the Installation section.
- (ii) The plate with the terminal connections label can now be removed by easing apart the longer sides of the module to release the interlocking tongue and groove.
- (iii) Note the location of the printed circuit board which must be replaced in the same position. Slide out the board.

Fuse replacement

The fuse holder is located at the edge of the circuit board adjacent to the mains transformer or low voltage power unit.

Fuse size: 20mm x 5mm dia.

Fuse ratings:

AC supply - 100mA Quick Blow

DC supply - 250mA Anti-surge

Changing AC supply voltage

Mains powered units can be adapted for operation on 110V, 220V or 230V supplies.



WARNING: Links for 110VAC and 220VAC must be insulated with silicon rubber sleeving.

Fig 1 provides details of the required link settings which are effected by soldered tinned copper wire links.

Replacing module cover

- (i) Replace the printed circuit board ensuring correct location in the module cover slots.
- (ii) Replace the plastic plate by locating the side with the two tongues around the protruding printed circuit board and engaging into the mating grooves.
- (iii) Press the plate home to engage the single tongue.

Fig 1 AC mains supply links

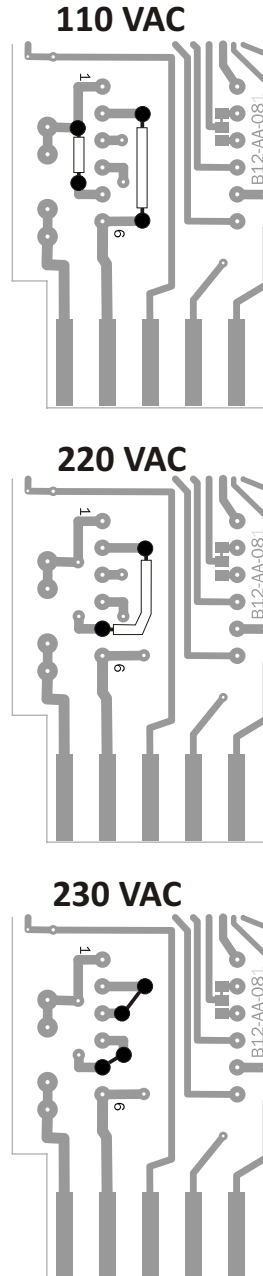

Specifications

Notes:

1. Output ranges are factory calibrated for one type of signal and not user configurable.

Outputs

0-10mA (2000R), 0-20 mA (1000R), 4-20 mA (1000R)

High impedance output drive options: 0-10mA (5000R), 0-20 mA (2500R), 4-20 mA (2500R)

Maximum output impedances in ohms shown in brackets.

0-5v, 1-5V, 0-10V, 2-10V (500R minimum)

Current sink 4-20mA @ 50 volts max.

Isolation

The output is isolated from the power supply.

Calibrated Accuracy

± 0.2% FSD at 100%.

Linearity Error

Set-point linearity error ± 0.25% FSD

Output Ripple

0.2% RMS of FSD

Load Resistance Effect

0.001% of span / 100 ohm change

Interference Rejection

Filtering is incorporated to attenuate R.F. and other industrial noise.

Temperature Coefficients

Zero: ± 0.02% span / °C, Span: ± 0.02% span / °C

Environmental

Temperature: operating -10 to +60°C,
storage -20 to +70°C

Humidity: 0 – 95% RH non-condensing

Power Supply

AC Supply: 110, 220 or 230V ±10% 50/60Hz 5VA

Fuse: 100mA quick-blow (internal)

Low voltage: 11-32VDC 4 W / 12-24VAC

Fuse: 250mA anti-surge (internal)

Supply Voltage Rejection

Span change: <0.02% span / % supply change.

Mechanical

Weight: approx. 0.5kg

Enclosure: Fire retardent materials -
PPO base, ABS cover

Screw terminal wire capacity: 2 x 1.5mm²